

**Barnegat Light® Hull Lights**  
**Model QL-60**  
**Parts and Installation Instructions**

**8005PM2**

REV. 3-1-06



Pat. Nos. 4,245,281 & 4,360,859

Model QL-60 Lights are designed for boats with a subtle flare in the bow--usually those with a hull 25' or longer.

**MODELS AVAILABLE**

MODEL NO.	PART NO.	DESCRIPTION	GE LAMP NO.	TOTAL WATTS PER LIGHT	TOTAL BEAM WIDTH IN DEGREES
QL-60-H7614	8005-105-000	Wide flood halogen sealed beam lamp	H7614	12V 50 W	70° W x 30° H
QL-60-H7604	8005-110-000	High candle power halogen spot lamp	H7604	12V 50 W	7° W x 5° H
QL-60-4502	8005-150-000	Flood halogen sealed beam lamp	4502	24V 50 W	7° W x 40°H

- Each 12V 50W lamp draws 3.91 amps
- Each 24V 50W lamp draws 2.08 amps
- Lights are used for docking and intermittent running
- Halogen lamps offer higher output than standard incandescent sealed beam lamps and have a higher "rated average life"

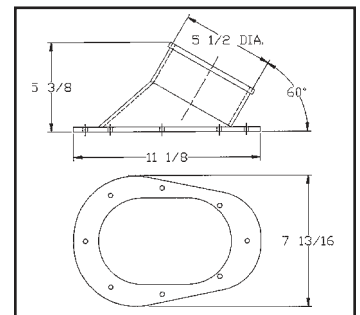
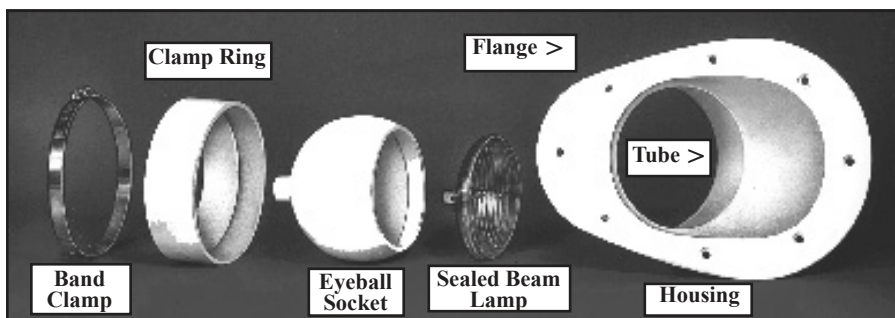

**COMPONENTS LISTING**

PART NO.	DESCRIPTION	QTY.	PART NO.	DESCRIPTION	QTY.
8005-000-105	Housing	1	8500-000-110	Flood Lamp H7614 or	1
8005-000-110	Eyeball	1	8500-000-140	Spot Lamp 24V, 4502	1
8005-000-115	Clamp Ring	1	9110-212520	#14 x 1-1/4 SMS, Pan Hd.	8
8005-000-120	Band Clamp	1	8005-000-125	Black Wire, 6", 16 Ga.	1
8500-000-105	Spot Lamp H7604 or	1	8005-000-130	White Wire, 6", 16 Ga.	1
			8005-000-135	Wire Terminals, #10 Eye Crimp	2

## INSTALLING QL-60 HULL LIGHTS

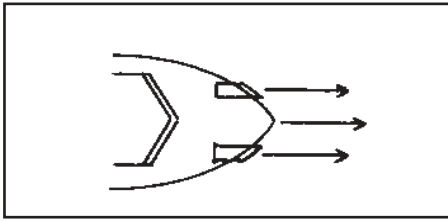

### INTRODUCTION: (Read carefully before installation)

The holes to be cut in the hull to accept the Hull-Light assembly should be as high above the water line and below the deck as is practical. The distance the lights mount back from the bow will vary with bow type and bluntness.

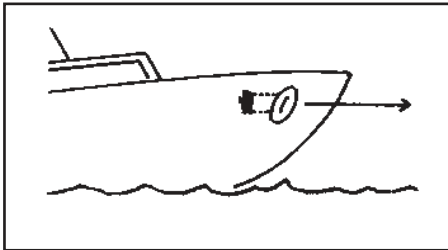

### ALIGNMENT (Distance back from bow)

The light assembly should be mounted far enough behind the bow so that the tube points straight ahead.

### ELEVATION (Angle of tilt up and down)

The tube should be parallel to the water at the planing or running speed. Use the tube as a level reference point.

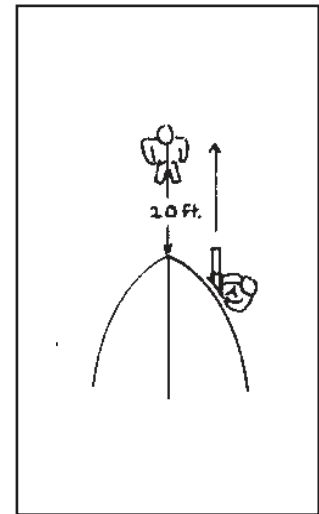

## INSTALLATION STEPS:

### 1. Laying out position of the lights on the hull

After reading previous introduction on alignment and elevation, locate approximate position for the oval hole on the sides of the hull. Check inside the hull for any wiring or obstructions before marking hull with template.

### 2. Marking hull for cutting (Template # 8005-000-200)

- Remove rubber eyeball socket, clamp ring and band clamp from rear of housing.
- Hold flange of housing against hull with tube facing forward.
- Move unit so that it is far enough back from bow so that tube points dead ahead.
- At this point level the tube so it is parallel to the water at running or planing speed. A person 20 ft. in front of boat can sight for correct alignment. Lights will shine in direction the tube is aimed or sighted.
- Circle flange and mark center line holes with grease pencil. Now using template, mark position of hole tube circumference to be cut for light assembly by circling template with pencil.

### 3. Checking before cutting

- With a tape measure check the height of front and back of each oval layout center line from top of the deck. Make sure measurements are the same for each side of boat. Now measure distances from bow of boat to front of each layout.
- Before cutting oval holes for light assembly, drill a 1/16" test hole in the hull using center line holes of the oval layout. Use care in locating these holes to avoid stringers and deck reinforcing ribs, etc.
- Examine the drilled holes from inside the hull to make sure that there's enough clearance for the tube part of the assembly which extends inside the hull.
- The rubber light sockets are slipped on and adjusted after the light assembly is permanently installed in hull.
- If oval layout should have to be moved, small holes can be plugged.

#### 4. Cutting through hull

- After final check for placement of oval layout, cut around same through hull with a Sabre or Keyhole saw.

#### 5. Final alignment and fitting

- After cutting holes in hull, file or rasp to dress out for inserting tube end of housing (with bulb and rubber socket removed).
- Hole should be dressed large enough so that assembly can be corrected slightly, if needed, for alignment and elevation before drilling mounting holes around flange. The housing flange should fit as close as possible against outside of hull.
- Do not hammer or attempt to bend flange. Hold assembly tightly in hull to check elevation and alignment.
  - ★ Tube part of assembly should be parallel to water line at planing or running speed when marking mounting holes.

#### 6. Locating mounting screws

- Hold the light housing firmly against hull and mark mounting holes through flange with pencil or punch.
- Make sure that the drilled holes are in the center of each hole in the flange. On wooden boats paint edges of drilled holes to prevent rotting.
  - ★ Before final installation of Hull-Lights run a bead of clear or white silicon caulking material around inside of flange. Silicon will spread with tightening of screws. Excess should be removed by wiping before it dries.

#### 7. Adjustments

- Alignment of bulbs (regular or fog) from inside of hull is accomplished by swiveling the eyeball and lamp inside the tube. (Use a silicon lubricant or baby powder on sockets for ease of movement.)
- With tightening bands removed and boat planing or running, adjust beams of light to your requirements.
- Be sure sockets are pushed onto assembly the correct amount before adjusting.
- After proper adjustment tighten band clamp securely around each clamp ring. Make sure that bands are placed forward of rear lip on housings before tightening.
- Replacement bulbs are available at all marine supply and auto parts stores. Soak bulb and socket in soapy water a few minutes for easy removal for bulb replacement.

**NOTE: Barnegat Light requires the use of silicon sealant where wires protrude from rear of eyeball socket. If the wires are pulled through the eyeball socket, for changing of lamp, the wire hole in the rear of the eyeball socket must be re-sealed, with silicon sealant, prior to re-assembly.**

#### **CAUTION:**

High candle power models have light beams up to 1,000 times brighter than "docking lights" with fixed flood bulbs. They are up to 30 times as bright as automobile headlights. Care and consideration for approaching boats must be exercised.

Consult your "Pilot Rules for Inland Waters," U.S. Department of Commerce, Bureau of Marine Inspection and Navigation or the U.S. Coast Guard for specific information about the rules governing bright lights.

## **ELECTRICAL REQUIREMENTS:**

Wattage (power consumption) of the model should be checked against battery and generator outputs. Batteries and generators must be in good condition and should be periodically checked. If daylight cruising time does not provide sufficient battery charge to maintain a high powered set of lights, a trickle charger may be used to keep the battery in top shape.

## **RECOMMENDED FUSE:**

2-50 W4 AG Fuse or circuit braker - 12 amp.

Lamps            THW stranded copper wire - 12 AWG.



Phone: (215) 493-2777 Fax: (215) 493-1401

Div. of ZIAMATIC CORP., 10 W. College Ave., P.O. Box 337, Yardley, PA, 19067